

Automotive Wire and Cable

A quick product finder

→ [ABS Cable](#)

→ [Transmission Wire](#)

→ [Primary Wire](#)

→ [Specialty Wire & Cable](#)



JUDD WIRE INC.



A member of the Sumitomo Electric Industries group of companies



Find the right Judd Wire product fast ABS Cable

As a complete integrated wire and cable manufacturer, Judd Wire can design a broad spectrum of special applications for OEM or replacement applications in the Automotive Industry. We can work within given specifications or create a combination of construction choices for our customers that allow them the best choice of material and performance attributes for their unique needs.

Our proprietary conductor exhibits very high flex life for desired applications. We offer unique jacket compounds to meet short excursion molding temperature up to 200°C and continuous operating temperature up to 150°C. Our various blends of insulation prevent melting or cracking during a molding process and are designed to easily form to different Nylon and Polyester compounds. Our cables provide superior flame resistance and are rated VW 1 testing parameters.

Our engineering expertise has made Judd Wire a leading supplier to many automotive platforms being built today. Our product designs range from simple discrete wire to complex cable constructions. We provide the most effective choices among materials, designs, manufacturing processes, test verifications and custom packaging to meet your standards.

For further information about our unique talents, please contact Judd Wire. We want to work with you to develop the right features and functions for your application.

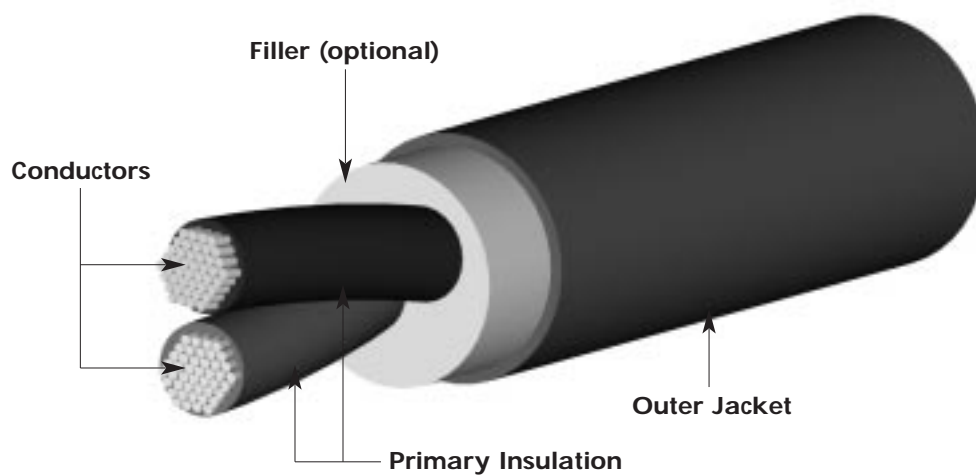

Typical ABS Cable Design

Typical Product Characteristics

- High Temperature
- Outstanding Fatigue and Flex life
- Superior Strength
- High Strength Alloy
- Excellent Abrasion, Pinch, and Crush Resistance

Typical Applications

- Active/Passive Sensor cable
- Wheel Bearings



ABS Cable

Judd	Gauge	Conductor		Type	Primary Insulation				Type	Outer Jacket				Type	
Part Number	Size	Stranding	Conductor Diameter			Nominal Thickness		Nominal Diameter			Nominal Wall		Nominal Diameter		
			inches	mm		inches	mm	inches	mm		inches	mm	inches	mm	
M7002000	20AWG	266	.042	1.07	CAL	.012	0.03	.066	1.68	XLFE	0.61	0.61	.180	4.57	XLPU
M7002001	.5mm ²	7	.036	0.91	TC	.016	0.04	.068	1.73	XLFE	0.74	0.74	.194	4.93	XLFE
M0702221	20AWG	266	.042	1.07	CAL	.020	0.51	.082	2.08	XLPE	1.02	1.02	.244	6.20	XLPU
M0702270	20AWG	266	.042	1.07	CAL	.020	0.51	.082	2.08	XLPE	1.02	1.02	.244	6.20	XLPU
M0002121	20AWG	266	.042	1.07	CAL	.020	0.51	.082	2.08	XLPE	1.02	1.02	.244	6.20	XLPE
M0702247	18AWG	41	.045	1.14	TC	.020	0.51	.085	2.16	XLPE	0.97	0.97	.246	6.25	PU
M0702295	20AWG	41	.035	0.89	TC	.021	0.53	.077	1.96	XLPE	1.13	1.13	.244	6.20	XLPE
M0702282	.3mm ²	60	.033	0.84	CAL	.017	0.43	.066	1.68	XLPE	0.86	0.86	.200	5.08	XLPE
M0702277	.3mm ²	60	.033	0.84	CAL	.017	0.43	.066	1.68	XLPE	0.86	0.86	.200	5.08	XLPE
M0702266	18AWG	19	.048	1.22	TC	.032	0.81	.112	2.84	XLPE	0.94	0.94	.299	7.59	PU
M0702271	18AWG	19	.048	1.22	TC	.032	0.81	.112	2.84	XLPE	0.94	0.94	.299	7.59	XLPE
M0702284	20AWG	266	.042	1.07	CAL	.018	0.46	.077	1.96	XLPE	1.14	1.14	.243	6.17	XLPE
M0702274	18AWG	41	.045	1.14	TC	.021	0.53	.086	2.18	XLPE	1.02	1.02	.252	6.40	XLPE
M0702258	20AWG	105	.042	1.07	BC	.021	0.53	.084	2.13	XLPE	1.02	1.02	.248	6.30	XLPE
M0702297	18AWG	19	.048	1.22	TC	.017	0.43	.082	2.08	XLPE	1.04	1.04	.246	6.25	XLPE
M0702316	.3mm ²	60	.033	0.84	CAL	.017	0.43	.066	1.68	XLPE	0.86	0.86	.200	5.08	XLPE
M0702351	22AWG	26	.029	0.74	TC	.014	0.36	.057	1.43	XLPE	0.84	0.84	.180	4.57	XLPE
M0702312	.3mm ²	60	.033	0.84	CAL	.017	0.43	.067	1.70	XLPE	0.84	0.84	.200	5.08	XLPE
M0702280	.3mm ²	161	.033	0.84	CAL	.019	0.48	.070	1.78	XLPE	0.81	0.81	.203	5.16	XLPE
M0702290	.5mm ²	41	.038	0.96	CAL	.019	0.48	.077	1.96	XLPE	1.14	1.14	.244	6.20	XLPE
M0702300	.5mm ²	20	.039	0.99	TC	.028	0.71	.095	1.78	XLPE	1.02	1.02	.270	6.86	XLPE
M0702311	20AWG	41	.035	0.89	TC	.021	0.53	.077	1.96	XLPE	1.14	1.14	.244	6.20	XLPE
M0704119	20AWG	266	.042	1.07	CAL	.018	0.46	.079	2.01	XLPE	1.19	1.19	.284	7.21	XLPE

- BC = ANNEALED BARE COPPER
- CAL = COPPER ALLOY
- TC = TIN COATED COPPER
- XLPU = POLYURETHANE, CROSSLINKED
- PU = POLYURETHANE, NON-CROSSLINKED
- XLPE = POLYOLEFIN, CROSSLINKED
- XLFE = FLOUROELASTOMER, CROSSLINKED

Superior Chemical, Mechanical, and Electrical Properties
 Cut-Through Resistance ■ Excellent Cut-Through Properties

Wear-Resistant Sensor cable ■ Ride Control cable



Find the right Judd Wire product fast Transmission Wire

As a complete integrated wire and cable manufacturer, Judd Wire can design a broad spectrum of special applications for OEM or replacement applications in the Automotive Industry. We can work within given specifications or create a combination of construction choices for our customers that allow them the best choice of material and performance attributes for their unique needs.

Our proprietary insulated compounds are designed to withstand short duration temperature usage of 250°C and constant operating temperature up to 200°C. Our unique designs can endure steady fluid temperature up to 150°C. We offer compounds that resist chemical attack, improve cut-through and non-deformation resistance.

Our engineering expertise has made Judd Wire a leading supplier to many automotive platforms being built today. Our product designs range from simple discrete wire to complex cable constructions. We provide the most effective choices among materials, designs, manufacturing processes, test verifications and custom packaging to meet your standards.

For further information about our unique talents, please contact Judd Wire. We want to work with you to develop the right features and functions for your application.

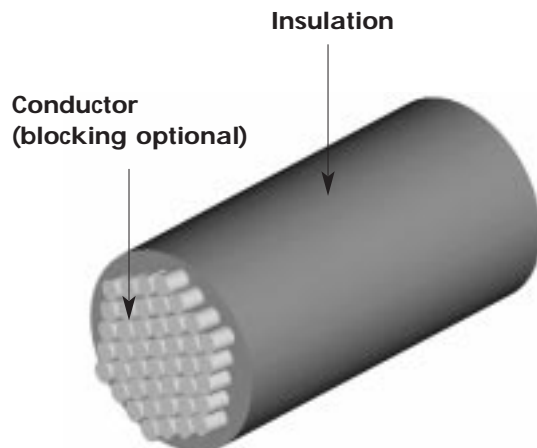

Typical Transmission Wire Design

Typical Product Characteristics

- High Temperature
- Outstanding Fluid Resistance
- Super Retardant
- High Durability
- Insulation Flexibility
- Outstanding Pinch, and Cut-Through Resistance



Transmission Wire

Judd	Gauge	Conductor		Type	Insulation		Type			
Part Number	Size	Stranding	Conductor Diameter			Nominal Thickness		Nominal Diameter		
			inches	mm		inches	mm	inches	mm	
H7000000	.8mm ²	19	.043	1.09	TC	.019	0.48	.080	2.03	XLFE
H7000001	.5mm ²	7	.037	0.94	TC	.015	0.38	.068	1.73	XLFE
H7000003	18AWG	19	.049	1.24	SBB	.016	0.41	.080	2.03	XLFE
H7000004	20AWG	7	.038	0.97	TC	.016	0.41	.070	1.78	XLFE
H0000105	20AWG	19	.038	0.97	TC	.016	0.41	.070	1.78	XLFE
H7000008	.5mm ²	7	.038	0.97	SBT	.015	0.38	.068	1.73	XLFE
H7000009	.5mm ²	19	.036	0.91	SBT	.017	0.43	.070	1.78	XLFE
H7000010	.5mm ²	7	.036	0.91	TC	.016	0.41	.070	1.78	XLFE
H7000016	8AWG	19	.043	1.09	TC	.019	0.48	.080	2.03	XLFE
H7000018	18AWG	19	.050	1.27	SBT	.016	0.41	.080	2.03	XLFE
H7000020	22AWG	19	.030	0.76	BC	.017	0.43	.064	1.63	XLFE
H4001160	16AWG	19	.054	1.37	SBB	.016	0.41	.085	2.16	ETFE
H7000017	18AWG	19	.050	1.27	SBT	.016	0.41	.080	2.03	XLFE
H7000024	12AWG	37	.088	2.24	SBT	.018	0.46	.123	3.12	XLFE
H0780180	5mm ²	105	.119	3.02	BC	.031	0.79	.180	4.57	XLPE

BC = ANNEALED BARE COPPER

SBT = SILICONE BLOCK TIN PLATED COPPER

SBB = SILICONE BLOCK BARE COPPER

TC = TIN COATED COPPER

XLPE = POLYOLEFIN, CROSSLINKED

XLFE = FLUOROELASTOMER, CROSSLINKED

ETFE = ETHYLENE TETRAFLUOROETHYLENE, NON-CROSSLINKED

ior Chemical, Mechanical, and Electrical Properties ■ Flame
ding Dimensional Characteristics ■ Excellent Abrasion,



Find the right Judd Wire product fast Primary Wire

As a complete integrated wire and cable manufacturer, Judd Wire can design a broad spectrum of special applications for OEM or replacement applications in the Automotive Industry. We can work within given specifications or create a combination of construction choices for our customers that allow them the best choice of material and performance attributes for their unique needs.

We offer a unique combination of high performance properties to meet high heat and burn through resistance. Our insulation will not melt or flow at hot soldering iron temperature of 350°C; consequently, rework due to soldering iron damage is eliminated. Our compounds are rated to temperatures of -55°C to 150°C for a wide range of applications. We offer various blends of compound to reduce creep caused by insulation stretching. Our insulated wire conforms easily to design shapes for chassis wiring and harness construction.

Our engineering expertise has made Judd Wire a leading supplier to many automotive platforms being built today. Our product designs range from simple discrete wire to complex cable constructions.

We provide the most effective choices among materials, designs, manufacturing processes, test verifications and custom packaging to meet your standards.

For further information about our unique talents, please contact Judd Wire. We want to work with you to develop the right features and functions for your application.

BC = ANNEALED BARE COPPER
TC = TIN COATED COPPER
XLPE = POLYOLEFIN, CROSSLINKED

Judd	Gauge	Conductor		Type	Insulation		Type			
Part Number SAE	AWG	Stranding	Conductor Diameter			Nominal Thickness		Nominal Diameter		
			inches	mm		inches	mm	inches	mm	
SXL										
H0779200	8	19	.133	3.38	BC	.045	1.14	.223	5.66	XLPE
H0779210	10	107	.123	3.12	BC	.043	1.09	.193	4.90	XLPE
H0779220	12	19	.089	2.26	BC	.039	0.99	.167	4.24	XLPE
H0779230	14	19	.068	2.26	BC	.037	0.94	.142	3.61	XLPE
H0779240	16	19	.054	1.37	BC	.034	0.79	.122	3.10	XLPE
H0779250	18	19	.048	1.22	BC	.032	0.81	.112	2.84	XLPE
H0779260	20	19	.038	0.97	BC	.031	0.79	.100	2.54	XLPE
GXL										
H0779400	8	19	.133	3.38	BC	.039	0.99	.211	5.36	XLPE
H0779410	10	19	.107	2.72	BC	.033	0.84	.173	4.39	XLPE
H0779420	12	19	.089	2.26	BC	.028	0.71	.145	3.68	XLPE
H0779430	14	19	.068	1.73	BC	.023	0.58	.114	2.90	XLPE
H0779440	16	19	.054	1.37	BC	.023	0.58	.100	2.54	XLPE
H0779450	18	19	.048	1.22	BC	.023	0.58	.094	2.39	XLPE
H0779460	20	19	.038	0.97	BC	.023	0.58	.084	2.13	XLPE
H0779700	8	19	.133	3.38	TC	.039	0.99	.211	5.36	XLPE
H0779710	10	19	.107	2.72	TC	.033	0.84	.173	4.39	XLPE
H0779720	12	19	.089	2.26	TC	.028	0.71	.145	3.68	XLPE
H0779730	14	19	.068	1.73	TC	.023	0.58	.114	2.90	XLPE
H0779740	16	19	.054	1.37	TC	.023	0.58	.100	2.54	XLPE
H0779750	18	19	.048	1.22	TC	.023	0.58	.094	2.39	XLPE
H0779760	20	19	.038	0.97	TC	.023	0.58	.084	2.13	XLPE
H0779701	8	133	.166	4.22	TC	.039	0.99	.244	6.20	XLPE
H0779711	10	105	.123	3.12	TC	.033	0.84	.189	4.80	XLPE
H0779721	12	65	.091	2.31	TC	.028	0.71	.147	3.73	XLPE
H0779731	14	41	.071	1.80	TC	.023	0.58	.117	2.97	XLPE
H0779741	16	26	.058	1.47	TC	.023	0.58	.104	2.64	XLPE
H0779751	18	41	.045	1.14	TC	.023	0.58	.091	2.31	XLPE
H0779761	20	41	.037	0.94	TC	.023	0.58	.083	2.11	XLPE
TXL										
H0779300	8	19	.133	3.38	BC	.024	0.61	.181	4.60	XLPE
H0779310	10	19	.107	2.72	BC	.022	0.56	.151	3.84	XLPE
H0779320	12	19	.089	2.26	BC	.020	0.51	.129	3.28	XLPE
H0779330	14	19	.068	1.73	BC	.018	0.51	.104	2.64	XLPE
H0779340	16	19	.054	1.37	BC	.018	0.46	.090	2.29	XLPE
H0779350	18	19	.048	1.22	BC	.018	0.46	.084	2.13	XLPE
H0779360	20	19	.038	0.97	BC	.018	0.46	.074	1.88	XLPE
H0779370	22	19	.030	0.97	BC	.018	0.46	.066	1.68	XLPE
H0779380	24	19	.024	0.61	BC	.018	0.46	.060	1.52	XLPE
H0779600	8	19	.133	3.38	TC	.024	0.61	.181	4.60	XLPE
H0779610	10	19	.107	2.72	TC	.022	0.56	.151	3.84	XLPE
H0779620	12	19	.089	2.26	TC	.020	0.51	.129	3.28	XLPE
H0779630	14	19	.068	1.73	TC	.018	0.46	.104	2.64	XLPE
H0779640	16	19	.054	1.37	TC	.018	0.46	.090	2.29	XLPE
H0779650	18	19	.048	1.22	TC	.018	0.46	.084	2.13	XLPE
H0779660	20	19	.038	0.97	TC	.018	0.46	.074	1.88	XLPE
H0779670	22	19	.030	0.76	TC	.018	0.46	.066	1.68	XLPE
H0779680	24	19	.024	0.61	TC	.018	0.46	.060	1.52	XLPE
H0779601	8	133	.166	4.22	TC	.024	0.61	.214	5.44	XLPE
H0779611	10	105	.123	3.12	TC	.022	0.56	.167	4.24	XLPE
H0779621	12	65	.091	2.31	TC	.020	0.51	.131	3.33	XLPE
H0779631	14	41	.071	1.80	TC	.018	0.46	.107	2.72	XLPE
H0779641	16	26	.058	1.47	TC	.018	0.46	.094	2.39	XLPE
H0779651	18	41	.045	1.14	TC	.018	0.46	.081	2.06	XLPE
H0779661	20	41	.037	0.94	TC	.018	0.46	.073	1.85	XLPE
H0779671	22	41	.029	0.74	TC	.018	0.46	.065	1.65	XLPE
H0779681	24	41	.024	0.60	TC	.018	0.46	.060	1.52	XLPE



Judd	Gauge	Conductor		Type	Insulation		Type			
Part Number JASO	mm ²	Stranding	Conductor Diameter			Nominal Thickness		Nominal Diameter		
			inches	mm		inches	mm	inches	mm	
AVSSX										
H030543	.5	19	.037	0.94	BC	.014	0.36	.064	1.63	XLPVC
H030506	.5	19	.037	0.94	BC	.013	0.33	.063	1.60	XLPVC
H030521	.5	7	.037	0.94	BC	.013	0.33	.063	1.60	XLPVC
H030544	.75	19	.046	1.17	BC	.013	0.33	.072	1.83	XLPVC
H030508	.75	19	.046	1.17	BC	.013	0.33	.072	1.83	XLPVC
H030503	.75	30	.045	1.14	TC	.021	0.53	.087	2.21	XLPVC
H030545	1.25	37	.058	1.47	BC	.013	0.33	.083	2.11	XLPVC
H030510	1.25	37	.058	1.47	BC	.013	0.33	.083	2.11	XLPVC
H030546	2	37	.069	1.75	BC	.017	0.43	.103	2.62	XLPVC
H030522	2	37	.069	1.75	BC	.017	0.43	.103	2.62	XLPVC
AVX										
H030538	3.0	41	.093	2.36	BC	.031	0.79	.155	3.94	XLPVC
H030556	5.0	65	.117	2.97	BC	.032	0.81	.181	4.60	XLPVC
H030563	8.0	154	.168	4.27	TC	.034	0.86	.236	5.99	XLPVC
H030551	10.0	154	.179	4.55	TC	.045	1.14	.268	6.81	XLPVC
H030552	15.0	84	.213	5.41	TC	.043	1.09	.299	7.59	XLPVC
H030529	20.0	247	.258	6.55	TC	.043	1.09	.345	7.59	XLPVC
H030530	.5	20	.039	0.99	BC	.039	0.99	.079	2.01	XLPVC
H030500	.5	20	.039	0.99	BC	.039	0.99	.079	2.01	XLPVC
H030505	.5	20	.039	0.99	TC	.019	0.48	.078	1.98	XLPVC
H030532	.75	30	.045	1.14	BC	.021	0.53	.087	2.21	XLPVC
H030502	.75	30	.045	1.14	BC	.021	0.53	.087	2.21	XLPVC
H030534	1.25	50	.059	1.50	BC	.024	0.61	.106	2.69	XLPVC
H030504	1.25	50	.059	1.50	BC	.024	0.61	.106	2.69	XLPVC
H030536	2.0	26	.074	1.88	BC	.025	0.64	.123	3.12	XLPVC
H030512	2.0	26	.074	1.88	BC	.025	0.64	.123	3.12	XLPVC
H030511	8.0	154	.168	4.27	TC	.035	0.89	.238	6.05	XLPVC
H030565	12.0	154	.197	5.00	BC	.040	1.02	.277	7.04	XLPVC
AVXTRA										
H030507	.75	30	.045	1.14	TC	.021	0.53	.087	2.21	XLPVC
H030541	.75	30	.045	1.14	TC	.021	0.53	.087	2.21	XLPVC
TVSSX										
H030549	.5	20	.039	0.99	TC	.019	0.48	.079	2.01	XLPVC
H030548	.5	19	.037	0.94	TC	.014	0.36	.064	1.63	XLPVC
H030520	.5	19	.037	0.94	TC	.013	0.33	.063	1.60	XLPVC
AEX										
H0781630	.5	20	.039	0.99	TC	.019	0.48	.079	2.01	XLPE
H0781632	.5	20	.039	0.99	TC	.019	0.48	.079	2.01	XLPE
H0781660	.5	20	.039	0.99	TC	.020	0.51	.079	2.01	XLPE
H0781700	1.25	50	.059	5.00	TC	.024	0.61	.087	2.21	XLPE
VX10										
H0305500	.10	63	.184	4.67	TC	.038	0.97	.026	0.66	XLPVC
AVFX										
H030527	8.0	154	.168	4.27	TC	.028	0.71	.224	5.69	XLPVC
H030528	15.0	171	.212	5.38	BC	.044	1.12	.300	7.62	XLPVC
TOKAI										
M0302372	.5	20	.039	0.99	BC	.019	0.48	.079	2.01	XLPVC
M0303358	.5	20	.039	0.99	BC	.019	0.48	.079	2.01	XLPVC
M0302356	.5	20	.039	0.99	BC	.019	0.48	.079	2.01	XLPVC
C0301356	.5		.039	0.99						
C0301357	.5	20	.039	0.99	BC	.019	0.48	.079	2.01	XLPVC
FLCEX										
H0782141	.85	11	.051	1.30	TC	.044	1.12	.138	3.51	XLPE
H0782121	2.0	26	.074	1.88	TC	.044	1.12	.161	4.09	XLPE
H0782111	3	41	.093	2.36	TC	.048	1.22	.189	4.80	XLPE
APXHTSHE										
C0701067	.5	20	.039	0.99	TC	.021	0.53	.081	1.48	XLPE
SHSXSHE										
C0301390	.5	19	.037	0.94	BC	.013	0.33	.063	1.60	XLPE
C0301392	.5	19	.037	0.94	BC	.013	0.33	.064	1.63	XLPVC
C0301394	.5	19	.037	0.94	BC	.013	0.33	.064	1.63	XLPVC
C0307350	.5	7	.037	0.94	BC	.021	0.53	.079	2.01	XLPVC
C0307351	.5	7	.037	0.94	BC	.021	0.53	.079	2.01	XLPVC
C0307352	.5	7	.037	0.94	BC	.021	0.53	.079	2.01	XLPVC
C0307353	.5	20	.039	0.99	BC	.019	0.48	.079	2.01	XLPVC
C0307354	.5	20	.039	0.99	BC	.019	0.48	.079	2.01	XLPVC
C0301340	.5	19	.037	0.94	BC	.013	0.33	.064	1.63	XLPVC
SHSXT										
M0302385	.5	19	.037	0.94	TC	.013	0.33	.063	1.60	XLPVC
M0302384	.5	19	.037	0.94	TC	.013	0.33	.063	1.60	XLPVC
M0302383	.5	19	.037	0.94	TC	.013	0.33	.063	1.60	XLPVC
M0302470	.5	19	.037	0.94	TC	.013	0.33	.063	1.60	XLPVC
M0302363	.5	19	.037	0.94	TC	.013	0.33	.063	1.60	XLPVC

Typical Product Characteristics

- High Temperature
- Outstanding Flexibility Properties
- Superior Chemical, Mechanical, and Electrical Properties
- Lightweight Construction
- Superior Flame Resistance
- Environmental Friendly- Halogen and Lead Free Design
- Excellent Abrasion, Pinch, and Cut-Through Resistance

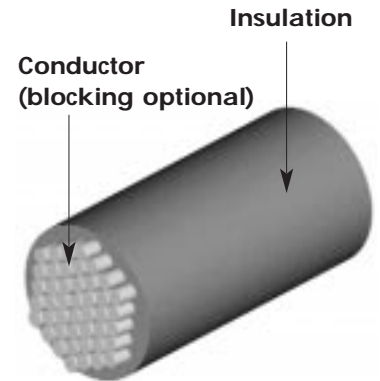

Typical Primary Wire Design

BC = ANNEALED BARE COPPER
 TC = TIN COATED COPPER
 XLPVC = POLYVINYL CHLORIDE, CROSSLINKED
 XLPE = POLYOLEFIN, CROSSLINKED



Find the right Judd Wire product fast Specialty Wire & Cable

As a complete integrated wire and cable manufacturer, Judd Wire can design a broad spectrum of special applications for OEM or replacement applications in the Automotive Industry. We can work within given specifications or create a combination of construction choices for our customers that allow them the best choice of material and performance attributes for their unique needs.

Our cross-linked irradiation technology enables our products to be highly dimensionally stable which improves abrasion and pinch requirements. Our products temperature range from -55°C to 250°C. Our proprietary conductors and compounds are aimed to meet and exceed specifications.

Our engineering expertise has made Judd Wire a leading supplier to many automotive platforms being built today. Our product designs range from simple discrete wire to complex cable constructions. We provide the most effective choices among materials, designs, manufacturing processes, test verifications and custom packaging to meet your standards.

For further information about our unique talents, please contact Judd Wire. We want to work with you to develop the right features and functions for your application.

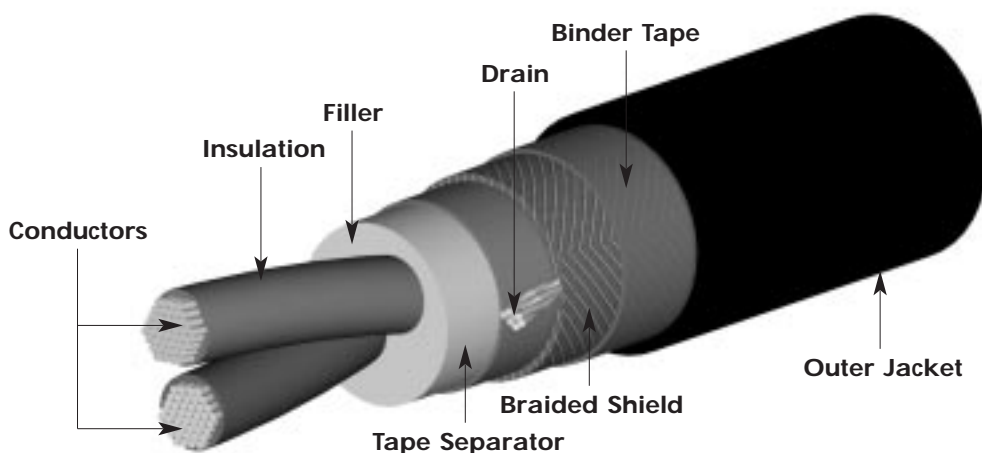

Available Design Features for Specialty Wires & Cables

Typical Product Characteristics

■ High Temperature ■ Outstanding Flexibility Properties ■ Superior Chemical, Mechanical, and Electrical Properties ■ Lightweight Construction and Dimensional Control ■ Superior Flame Resistance ■ Environmental Friendly- Halogen and Lead Free Design ■ Excellent Abrasion, Pinch, and Cut-Through Resistance ■ Improved Deformation and Shrink-back Properties ■ Excellent Shield Effectiveness and EMI, RF and Low Frequency Characteristics

Typical Applications

■ Wheel Speed Sensor Cable ■ Side Air Bag Ignitor Wire ■ Seatbelt Pretension and Frontal Air Bag Wire ■ Gas Tank Wire ■ Fuselink ■ Databus ■ Battery Cable ■ Steering Wheel Wire ■ Temperature Sensor Cable ■ Chassis Sensor Cable ■ Tire Sensor Cable ■ Shielded and Blocked Cable ■ Bearing Grease Wire ■ DLX Wire ■ Sliding Door Sensor Cable ■ Electronic Fan Drive Cable

Specialty Wire & Cable



Judd	Gauge	Conductor		Type	Insulation		Type	
Part Number	Size	Stranding	Conductor Diameter inches mm		Nominal Thickness inches mm	Nominal Diameter inches mm		
WHEEL SPEED SENSOR CABLE								
M0702234	.5mm ²	7	.037	0.94	BC	.016 0.41	.069 1.75	XLPE
M0704102	.35mm ²	7	.029	0.74	HBC	.016 0.41	.060 1.52	XLPE
M0704104	.35mm ²	7	.029	0.74	HBC	.015 0.38	.060 1.52	XLPE
M0702268	.35mm ²	7	.029	0.74	HBC	.015 0.38	.060 1.52	XLPE
SIDE AIR BAG								
M0302390	.35mm ²	20	.039	0.99	TC	.019 0.48	.078 1.98	XLPE
M0302392	.5mm ²	20	.039	0.99	TC	.019 0.48	.078 1.98	XLPE
M0302395	.5mm ²	20	.039	0.99	TC	.019 0.48	.078 1.98	XLPE
M0302396	.5mm ²	20	.039	0.99	TC	.019 0.48	.078 1.98	XLPE
M0302340	.5mm ²	19	.037	0.94	BC	.013 0.33	.063 1.60	XLPE
M1202304	20AWG	7	.037	0.94	BC	.015 0.38	.067 1.70	PVC
SEATBELT PRETENSION & FRONTAL AIR BAG WIRE								
H0305050	.5mm ²	20	.039	0.99	TC	.019 0.48	.078 1.98	XLPE
H0305060	.5mm ²	19	.037	0.94	BC	.013 0.33	.063 1.60	XLPE
H0779101	20AWG	7	.037	0.94	BC	.025 0.64	.086 2.18	XLPE
H0305086	.75mm ²	19	.046	1.17	BC	.013 0.33	.072 1.83	XLPE
H0305850	.85mm ²	11	.049	1.24	BC	.021 0.53	.091 2.31	XLPE
H0780096	18AWG	41	.045	1.14	TC	.024 0.61	.092 2.34	XLPE
H0780303	20AWG	7	.038	0.97	TC	.024 0.61	.086 2.18	XLPE
H0783500	14AWG	19	.068	1.73	BC	.017 0.43	.102 2.59	XLPE
GAS TANK WIRE								
H0779110	14AWG	19	.068	1.73	BC	.016 0.41	.100 2.54	XLPE
H0779114	16AWG	19	.057	1.45	BC	.016 0.41	.089 2.26	XLPE
H0779111	.8mm ²	19	.045	1.14	BC	.016 0.41	.078 1.98	XLPE
H0779170	.8mm ²	19	.045	1.14	BC	.016 0.41	.078 1.98	XLPE
H0779171	.8mm ²	19	.045	1.14	BC	.016 0.41	.078 1.98	XLPE
H0779172	.8mm ²	19	.045	1.14	BC	.016 0.41	.078 1.98	XLPE
H0779185	16AWG	19	.054	1.37	BC	.018 0.46	.089 2.26	XLPE
H0779187	14AWG	19	.068	1.73	BC	.018 0.46	.102 2.59	XLPE
H0779180	.8mm ²	19	.045	1.14	BC	.017 0.43	.078 1.98	XLPE
H0779920	14AWG	19	.066	1.68	SPC	.019 0.48	.103 0.33	XLPE
H0779930	.8mm ²	19	.045	1.14	BC	.016 0.41	.078 1.98	XLPE
H0779931	22AWG	7	.030	0.76	SPC	.016 0.41	.062 1.57	XLPE
FUSELINK								
H0722050	14AWG	19	.068	1.73	BC	.043 1.09	.153 3.89	XLPE
H0722092	12AWG	19	.090	2.29	BC	.046 1.17	.182 4.62	XLPE
H0722070	5mm ²	19	.107	2.72	BC	.050 1.27	.207 5.26	XLPE
H0722094	8mm ²	37	.132	3.35	BC	.050 1.27	.233 5.86	XLPE
DATABUS J1939 & CAN CABLE								
M0702301	.5mm ²	20	.039	0.99	TC	.028 0.71	.095 2.41	XLPE
M0704116	20AWG	19	.038	0.97	TC	.023 0.58	.084 2.13	XLPE
M0704120	20AWG	19	.038	0.97	BC	.023 0.58	.084 2.13	XLPE
M0702001	18AWG	19	.048	1.22	TC	.046 1.17	.140 3.55	XLPE
BATTERY CABLE								
H0780074	62mm ²	266	.469	3.73	BC	.076 1.93	.620 6.60	XLPE
H7000200	32mm ²	192	.281	7.14	BC	.044 1.12	.369 8.36	XLPE

BC = ANNEALED BARE COPPER
 TC = TIN COATED COPPER
 SPC = SILVER PLATED COPPER
 HBC = HARD DRAWN BARE COPPER
 PVC = POLYVINYL CHLORIDE, NON-CROSSLINKED
 XLPE = POLYVINYL CHLORIDE, CROSSLINKED
 XLPE = POLYOLEFIN, CROSSLINKED
 XLFE = FLUOROELASTER, CROSSLINKED

Production Process of Automotive Wire

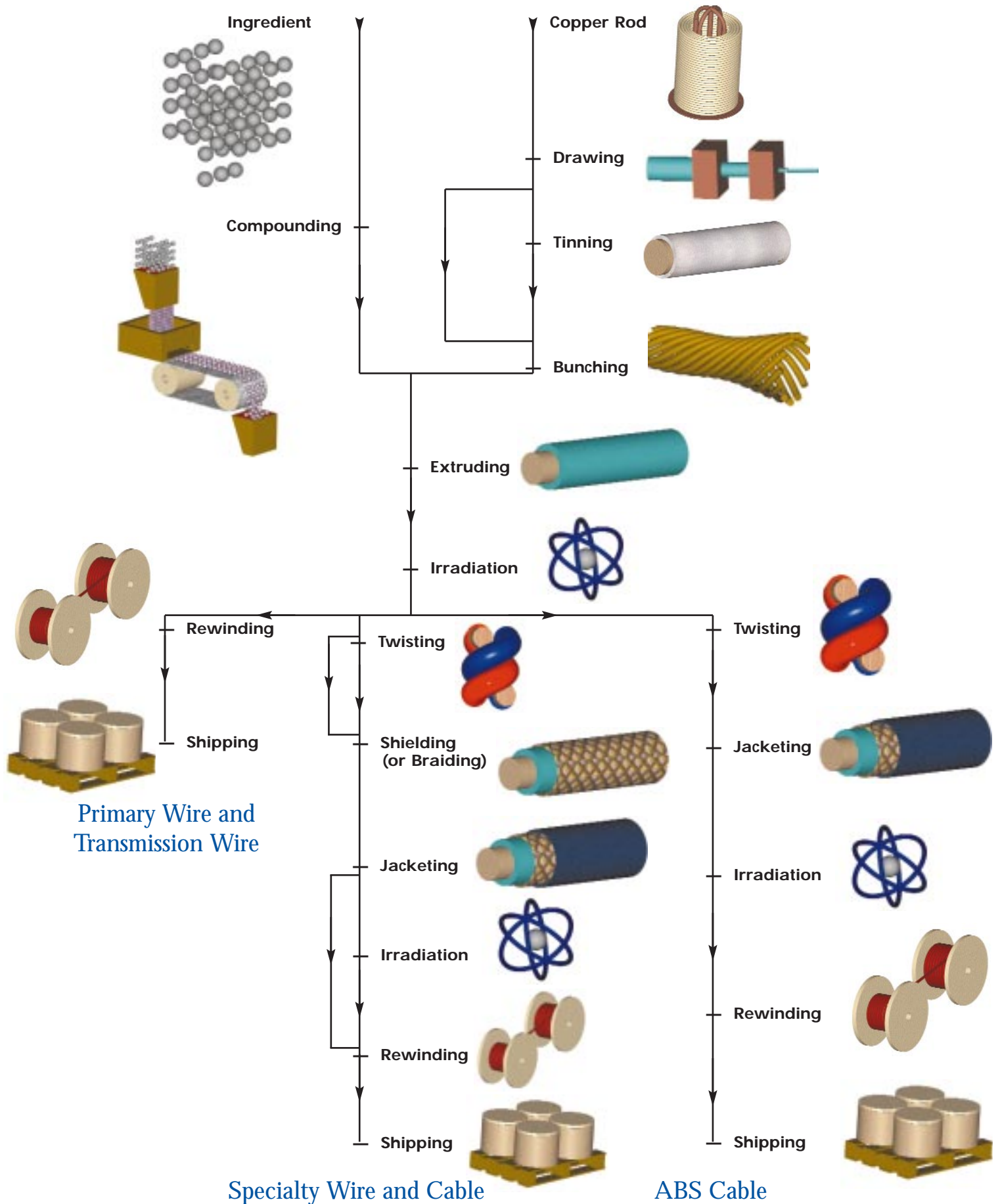

Production Process of Automotive Wire



Judd Wire – Pioneer in Irradiated Wire

Judd Wire, a wire and cable manufacturer, specializes in electron beam cross-linked irradiation technology for wire insulation. Judd designs a broad spectrum of products recognized by Underwriters Laboratory, Canadian Standards and/or Military Specifications.

Electron Beam Technology and Cross-Linked Wire Insulation

Electron beam processing evolved from the particle accelerator into a variety of industrial applications worldwide. One of its major uses is the irradiation of electrical insulation materials – the specialty of Judd. Electron beam treatment changes both the chemical structure and physical properties of wire insulation. The principal effect of high velocity electrons is to break the existing chemical bonds between the atoms of insulation materials. Orbital electrons are liberated, producing ions and free radicals. The free radicals react with other molecules creating long chains and crosslinks between molecules. The resulting crosslinked material exhibits thermosetting properties. In the case of insulation materials for wire and cable, the beneficial results of this irradiation cross-linking are: improved resistance to cut-through, deformation and chemical attack; no shrink-back or melting even when the insulation is in direct contact with a hot soldering iron at 349°C (660°F).



Judd Wire Inc.
Headquarters and Manufacturing Facility
124 Turnpike Road
Turners Falls, MA 01376-2699 USA
Telephone (413) 863-4357
1- 800 545-5833
Fax (413) 863-2305



Judd Wire Inc.
870 Los Vallecitos Boulevard
San Marcos, CA 92069 USA
Telephone (760) 744-7720
1- 800 344-5251
Fax (760) 744-6089

Judd Wire Inc. is an ISO 9001 and QS 9000 Registered Firm

Company Profile

Today's Judd Wire Inc. started out as the Judd Wire Manufacturing Company, founded by Thomas Judd in 1953 in a 1,000 square foot warehouse in downtown Turners Falls, MA. He had one extruder, one respooler, and for the next three years, a single customer who purchased steel insulated wire, which was used as a support member in vacuum cleaner hoses.

Early in 1962, he opened a new 20,000 square foot facility on the site where the factory remains today. Sales took off and the plant size doubled in just two years!



Business had grown to include products for the telephone industry, automobiles (ignition cables, antenna leads and wire harnesses), and electronics (lead wires, elevator cables and traffic signal cables).

The real growth of Judd was still to come. In September of 1967, Tom Judd sold the business to Electronized Chemical Corporation. ECC was a manufacturer of plastic compounds and the innovators of a new product, Irradiation Crosslinked heat shrink tubing. Their new Judd Wire division became an industry source of Irradiated PVC (XLPVC) wire.

The concept of irradiating wire to improve its resistance to heat and allowing it to be easily processed helped Judd Wire capture approvals and contracts with manufacturers in the emerging computer and telecommunications industries.

In 1971, Judd Wire's capabilities increased with the installation of our first particle accelerator for crosslinking wire. This machine was supplied by High Voltage Engineering, the parent company of ECC. In 1977, the purchase of another plant in Escondido, California gave Judd Wire a Manufacturing presence on both coasts of the United States. This facility was expanded and moved to San Marcos in 1980.

High Voltage Engineering was purchased by a group of investors in early 1988, and the future of the Judd Wire division was unknown. A sale to another company was inevitable, but how would that new parent see Judd Wire?

The bad news became great news when in August of 1988, the announcement was made that the Judd Wire Division of High Voltage Engineering had been sold to Sumitomo Electric U.S.A.



Sumitomo Electric U.S.A. (SEUSA), with the guidance of Sumitomo Electric Industries of Japan, supported an immediate program of growth and modernization of both Judd Wire factories. New buildings, manufacturing equipment and new computer systems were all introduced. But more important than any of the structures and equipment, Sumitomo Electric and Judd Wire Inc. have invested in the people that make these products.

Today, the employees of Judd Wire Inc. are an integral part of the company, responsible for writing the operating systems that govern the quality and manufacturing processes, as well as developing the designs and the materials which have fueled this decade of growth.

Judd Wire Inc. now employs over 450 people in two modern, state-of-the-art facilities. Judd Wire products are used throughout the globe in some of the most technically complex and demanding applications in our industries.

Our customers in such markets as Automotive, Aerospace, Telecommunications, Data Processing, Consumer Electronics, Medical Imaging, Industrial Controls and many others can count on Judd Wire Inc. and Sumitomo Electric to be the leaders in wire and cable applications.

As proud as we are of our past, we remain committed to our future. The horizon is full with opportunities that will allow Judd Wire Inc. to achieve our mission of continuous improvement and total customer satisfaction.





JUDD WIRE INC.

Judd Wire Inc.

Headquarters and Manufacturing Facility

124 Turnpike Road

Turners Falls, MA 01376-2699 USA

Telephone (413) 863-4357

1-800 545-5833

Fax (413) 863-2305

Judd Wire Inc.

870 Los Vallecitos Boulevard

San Marcos, CA 92069 USA

Telephone (760) 744-7720

1-800 344-5251

Fax (760) 744-6089

web: www.juddwire.com

Automotive References

→	Conductor Reference	page 1
→	Insulation Reference	page 5
→	Part Number System Reference	page 6
→	Cross-Reference Guide	page 7
→	Conversion Reference	page 10
→	Glossary	page 12
→	Certification	page 16
→	Automotive Application Sheet	page 17



JUDD WIRE INC.



A member of the Sumitomo Electric Industries group of companies

Stranding Definitions

Unilay Stranding

Conductor constructed with a central core surrounded by more than one layer of helically laid single-end wires. All layers have a common direction of lay and the same length of lay.

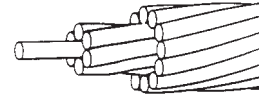

unilay and unidirectional

Unidirectional Stranding

Conductor constructed with a central core surrounded by more than one layer of helically laid single-end wires. All layers have a common direction of lay.

Bunched Stranding

A collection of wire or cable elements twisted together in the same direction without predetermined pattern.



bunched

Concentric Stranding

A central wire or core surrounded by one or more layers of helically laid wires.

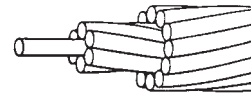

concentric

Rope Stranding

A concentric-stranded construction with component wires stranded.

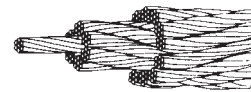

rope

Effects of Stranding

Unilay Stranding and Unidirectional Stranding

Electrical Conductivity: Slightly lower than true concentric; higher conductivity than bunched for 18 gauge and finer, lower for 16 gauge through 10 gauge. **Diameter Control:** Best in diameter control and smaller diameters. **Weight Control:** Best weight control and lowest weight for equivalent conductivity. **Flexibility:** Higher flexibility than true concentric or bunched with fewer strands. **Crimp Termination:** Concentric strandings are best for crimping due to less "give." **General:** Excellent diameter control and very smooth surface; used for thin wall insulations, both extruded and tape wrapped.

Bunched Stranding

Electrical Conductivity: Designed to have same conductivity as equivalent solid gauges. **Diameter Control:** Poor diameter control because of non-geometric configuration. **Weight Control:** Poor weight control but usually not important for bunched. **Flexibility:** Dependent upon number of strands; more strands equals better flexibility. **Crimp Termination:** Poor for quality crimp terminations, usually soldered. **General:** Generally used for lower temperature, heavier insulation thickness.

Concentric Stranding

Electrical Conductivity: Slightly higher than unilay; same comparison with bunched as unilay. **Diameter Control:** Better than bunched or ropes. **Weight Control:** Good weight control. **Flexibility:** Least flexibility when compared to other types of stranding with the same number of strands. **Crimp Termination:** Concentric strandings are best for crimping due to less "give." **General:** Very good diameter control and smooth surface; used for thin wall insulations, both extruded and tape wrapped.

Rope Stranding

Electrical Conductivity: Generally designed to have same conductivity as equivalent solid gauges except 19 x 7 end construction, which is greater. **Diameter Control:** Dependent upon configuration; generally more strands means less control. **Weight Control:** Dependent upon configuration; generally more strands means less control. **Flexibility:** Best flexibility due to greater number of strands. **Crimp Termination:** Generally good for crimping because of mass, depending upon configuration. **General:** Can be used with any insulation, depending upon configuration.

Conductor AWG Reference Chart

**DC RESISTANCE
AT 20°C
(MAXIMUM)

SIZE	NUMBER OF STRANDS	SINGLE END SIZE	CONFIGURATION	DIAMETER	CIRCULAR MIL AREA	WEIGHT	
						ANNEALED	BARE COPPER
AWG	AWG/inches		type	inches	cmils	lbs/kft	ohms/kft
22	7	30	concentric	0.030	707	2.17	15.6
22	19	34	unilay	0.030	763	2.41	15.1
20	7	28	concentric	0.038	1170	3.57	10.0
20	19	32	unilay	0.038	1216	3.84	9.20
18	7	26	concentric	0.046	1788	5.63	6.30
18	19	30	unilay	0.048	1920	6.06	5.80
16	19	29	unilay	0.054	2452	7.73	4.52
14	19	27	unilay	0.068	3991	12.2	2.87
14	19	0.0147	unilay	0.070	4151	13.1	2.87
12	19	25	unilay	0.085	6151	19.4	1.81
12	37	28	unidirectional	0.084	5936	18.7	1.90
10	37	26	unidirectional	0.111	10487	32.2	1.19
8	133	19x7/29	rope	0.169	16851	51.8	0.66
6	133	19x7/27	rope	0.208	26880	82.5	0.42
4	133	19x7/25	rope	0.263	42560	131	0.26
2	665	19x35/30	rope	0.328	66833	208	0.17
1	817	19x43/30	rope	0.367	82109	254	0.11
1/0	1045	19x55/30	rope	0.410	105023	326	0.108
2/0	1330	19x70/30	rope	0.457	133665	417	0.085
3/0	1665	37x45/30	rope	0.520	166931	525	0.068
4/0	2109	37x57/30	rope	0.581	211452	652	0.054

**DC Resistance given for Annealed Bare Copper, also available for Tin Coated Copper and Nickel Plated Copper.

Tabulation of Cable-Shield Qualities Chart

QUALITY	COPPER BRAID	COPPER SERVED	CONDUCTIVE TEXTILE	ALUMINUM/MYLAR FOIL	CONDUCTIVE PLASTIC	SOLID SHEATH
Shield Effectiveness Low Frequency	Good	Good	Fair	Excellent	Fair	Excellent
Shield Effectiveness RF	Good	Poor	Poor	Excellent	Poor	Excellent
Normal Percent of Coverage	60-95%	90-97%	100%	100%	100%	100%
Fatigue Life	Good	Fair	Excellent	Fair*	Good	Poor
Tensile Strength	Excellent	Fair	Poor	Poor	Poor	Excellent
Termination Method	Comb & Pigtail	Pigtail	Drain Wire	Drain Wire	Drain Wire	Clamp

* Special techniques can provide excellent fatigue life for use in retractile cords.

Common Conductor Material

MATERIAL	ASTM STD	SAE STD	TEMPERATURE RATING (°C)	TENSILE STRENGTH NOMINAL (MPa)	CONDUCTIVITY % IACS*	FLEXURE ENDURANCE (ASTM 470)
a) Annealed Bare Copper	B3	J1127-J1128	150	235	100%	852 cycles (reference)
b) Hard Drawn Bare Copper	B1	J1127-J1128	150	450	100%	1.2 times greater than Annealed Bare Copper
c) Tin Coated Copper	B33	J1127-J1128	150	235	93-97%	852 cycles (estimated)
d) Silver Plated Copper	B298	N/A	200	235	100%	852 cycles (estimated)
e) Nickel Plated Copper	B355	J1127-J1128	150	235	91-96%	852 cycles (estimated)
f) Nickel Plated High Strength Alloy	B624	J1127-J1128	200	415	85-86%	5 times greater than Annealed Bare Copper
g) CA Flexible Alloy	N/A	N/A	150	490	83%	4.5 times greater than Annealed Bare Copper

* National Bureau of Standard HB100

Note: Flex life will, in general, be improved by use of higher strength material. Theoretically, annealed material will have longer fatigue life than hard. However, in practice the stiffness of hard material frequently tends to restrict the sharpness of bend, resulting in improved life.

Conductor Metric Reference Chart

**DC RESISTANCE
AT 20°C
(MAXIMUM)

ANNEALED
BARE COPPER

METRIC SIZE	NUMBER OF STRANDS	SINGLE END SIZE	CONFIGURATION	DIAMETER SECTIONAL AREA	CROSS SECTIONAL AREA	WEIGHT	ohms/km
mm ²		mm	type	mm	mm ²	kg/km	ohms/km
0.3	19	0.16	unilay	0.78	0.38	3.14	48.8
0.3	49	0.10	rope	0.91	0.39	3.52	50.5
0.3	60	0.08	rope	0.84	0.31	2.72	77.0 *
0.35	7	0.25	concentric	0.73	0.35	3.14	50.5
0.5	7	0.32	concentric	1.00	0.60	5.36	32.7
0.5	19	0.19	unilay	0.94	0.54	4.82	36.7
0.5	20	0.18	bunched	1.00	0.50	4.55	36.7
0.5	41	0.13	bunched	0.96	0.53	4.78	40.9 *
0.5	266	0.05	rope	1.07	0.54	5.36	44.0 *
0.75	19	0.23	unilay	1.14	0.79	7.14	24.4
0.75	30	0.18	bunched	1.20	0.76	6.83	24.4
0.8	7	0.38	concentric	1.13	0.78	7.05	22.5
0.8	16	0.25	bunched	1.16	0.79	7.07	23.0
0.8	19	0.23	unilay	1.13	0.81	7.31	21.9
0.85	11	0.32	bunched	1.20	0.88	7.99	20.8
1.00	19	0.28	unilay	1.33	1.18	10.6	15.1
1.25	16	0.32	bunched	1.50	1.29	11.6	14.3
1.25	19	0.29	unilay	1.47	1.32	11.8	14.7
1.25	37	0.21	unidirectional	1.41	1.33	12.0	14.7
1.25	50	0.18	bunched	1.50	1.27	11.4	14.7
1.5	19	0.307	unilay	1.45	1.41	13.9	12.7
2.0	19	0.36	unilay	1.71	1.95	17.5	9.30
2.0	26	0.32	bunched	1.88	2.12	19.0	8.60
2.0	37	0.32	unidirectional	1.90	2.09	18.1	8.81
3.0	19	0.45	unilay	2.14	3.05	27.3	5.82
3.0	37	0.34	unidirectional	2.25	3.28	25.4	5.58
3.0	41	0.32	bunched	2.40	3.30	29.5	5.59
5.0	65	0.32	bunched	3.00	5.23	47.2	3.52
5.0	19	0.57	unilay	2.68	4.78	42.9	3.68
8.0	19	0.71	unilay	3.38	7.60	68.4	2.34
8.0	37	0.51	unidirectional	3.34	7.45	67.1	2.42
8.0	50	0.45	bunched	3.70	7.95	70.5	2.32
8.0	154	0.26	rope	4.27	8.19	73.6	2.33
10.0	63	0.45	rope	4.09	10.0	90.8	1.91
10.0	189	0.26	rope	4.29	10.1	88.8	1.99
12.0	154	0.32	rope	5.32	12.5	112.6	1.44
13.0	37	0.66	unidirectional	4.37	12.8	114.4	1.40
15.0	171	0.31	rope	5.40	13.2	120.2	1.37
19.0	133	0.43	rope	6.07	19.3	177.4	0.94
32.0	133	0.57	rope	8.35	34.3	312.0	0.56
50.0	299	0.46	rope	9.07	49.6	520.9	0.39
50.0	342	0.43	rope	10.3	49.5	454.0	0.36
62.0	266	0.57	rope	11.83	66.7	609.4	0.27
81.0	342	0.57	rope	14.00	85.8	781.8	0.21
103.0	342	0.63	rope	15.18	106.7	982.0	0.17

** DC Resistance given for Annealed Bare Copper, also available for Tin Coated Copper and Nickel Plated Copper.
* Copper Alloy Conductor Construction used.

4 Conductor Coatings Chart

Heavy Tinned

Individual strands doubly tinned then twisted

Top Coat

Bare strands twisted together then tinned overall

Overcoat

Strands individually tinned, twisted together and then tinned overall

Fused

Strands doubly tinned, twisted together and then fused together

TYPE	COST	OXIDATION	SOLDER	COMMENT
Annealed Bare Copper (no coating)	low	rapid	difficult	high contact resistance
Tin Coated Copper	moderate	resistant	easy	low contact resistance
Silver Plated Copper	very high	resistant	easy	low RF loss, higher than 200°C
Nickel Plated Copper	high	resistant	discourages wicking	not recommended for high vibration applications, good for crimping

Characteristics and Comparisons of Conductors

TYPE	LIFE STABILITY	CRIMP TERMINATION	SOLDERBILITY
Annealed Bare Copper (BC)	Excellent- Slight loss of conductivity with heat aging.	Excellent- Contact resistance may vary with type of terminal.	Good- When clean.
Hard Drawn Bare Copper (HBC)	Good- Slight loss of conductivity with heat aging.	Good- Contact resistance may vary with time.	Poor- Crimp termination preferred.
Tin Coated Copper (TC)	Conductivity and solderability deteriorates with heat aging at rated temperature due to migration of tin and copper and tin oxidation.	Good- But contact resistance increases with time and can be variable.	Good originally. Deteriorates with shelf life.
Silver Plated Copper (SPC)	Excellent- no loss of conductivity with heat aging at rated temperature. Solderability shelf life remains good.	Excellent- Contact resistance remains low.	Excellent.
Nickel Plated Copper (NPC)	Conductivity remains stable with heat aging at rated temperature.	Good- Contact resistance may vary with time. Use plated steel terminal in some cases.	Requires active flux.
Silicone Blocked Bare Copper (SBB)	Excellent- Slight loss of conductivity after heat aging.	Very Good- Contact resistance may vary with type of terminal and degree of cleaning.	Poor- Crimp termination preferred.
Silicone Blocked Tinned Copper (SBT)	Excellent- Slight loss of conductivity after heat aging.	Very Good- Contact resistance may vary with type of terminal and degree of cleaning.	Poor- Crimp termination preferred.
Copper Alloy (CAL)	Good- Slight loss of conductivity after heat aging.	Good- Contact resistance may vary with time.	Poor- Crimp termination preferred.

Insulation Classifications

Based on crosslinking degree and reprocessing abilities, polymers can be divided into three groups:

TYPE	CHARACTERISTICS	BENEFITS
Thermoplastics	<ul style="list-style-type: none"> Chemically non-crosslinked Melt repeatedly upon heating Soluble in suitable solvents 	<ul style="list-style-type: none"> Low cost Reprocessable
Thermosets	<ul style="list-style-type: none"> Fully cross-linked in chemical structure Non-melt upon heating Swellable but insoluble in solvents 	<ul style="list-style-type: none"> Improved heat resistance Increased tensile strength Improved cut-through and abrasion resistance Increased chemical resistance
Elastomer	<ul style="list-style-type: none"> Chemically or physically crosslinked Generally having properties in between thermoplastics and thermosets depending on structure 	<ul style="list-style-type: none"> High elasticity and flexibility High elongation

Insulation Type

TYPE	CODE	MAXIMUM CONTINUOUS OPERATING TEMPERATURE (°C)	SPECIAL OPTIONS	TENSILE STRENGTH MPa	ELONGATION (%)	FLAME RESISTANCE	PINCH ABRASION RESISTANCE	TYPE	CHEMICAL RESISTANCE
Polyvinyl Chloride, non-crosslinked	PVC	90-105	▼▲■	15-20	220-330	3	1	TP	1
Polyvinyl Chloride, crosslinked	XL PVC	105	▼▲■	18-25	150-450	3	2	TS	2
Chlorinated Polyethylene, crosslinked	XL CPE	105	▼■	18-25	250-400	3	2	TS	2
Thermoplastic Elastomer crosslinked	TPE	90-105	▼❖*	8-20	300-500	0-1	1	E	0-1
High Density Polyethylene	HDPE	90	▼❖*	28-35	500-800	0	1-2	TP	2-3
Polyolefin, crosslinked	XL PE	125-150	▼❖*	10-25	250-350	1-3	2-3	TS	2-3*
Polyamide, non-crosslinked	PA	105	▼	15-25	150-300	2-3	3	TP	2-3
Polyurethane, non-crosslinked	PU	80-90	❖▼*	25-55	400-700	2-3	3	E	1
Polyurethane, crosslinked	XL PU	105	❖▼*	25-35	300-450	2-3	3	TS	2
Polyester, crosslinked	XL PES	150	▼❖■	25-30	300-400	2	3	TS	2
Chlorotrifluoroethylene /ethylene copolymer, non-crosslinked	ECTFE	150	▼	39-55	250-380	3	3	TP	3
Fluoropolymer, non-crosslinked	FP	150-250	▼	35-55	150-350	3	3	TP	3
Fluoroelastomer, crosslinked	XL FE	150-200	▼	15-35	200-400	3	2	TS	3

▲ Leaded ■ Lead-free ❖ Halogenated * Halogen-free ▼ Ozone resistant
 0 = POOR 1 = GOOD 2 = BETTER 3 = BEST * fuel resistant product available
 TP = Thermoplastic TS = Thermoset E = Elastomer

Part Numbering System

building A Primary Wire

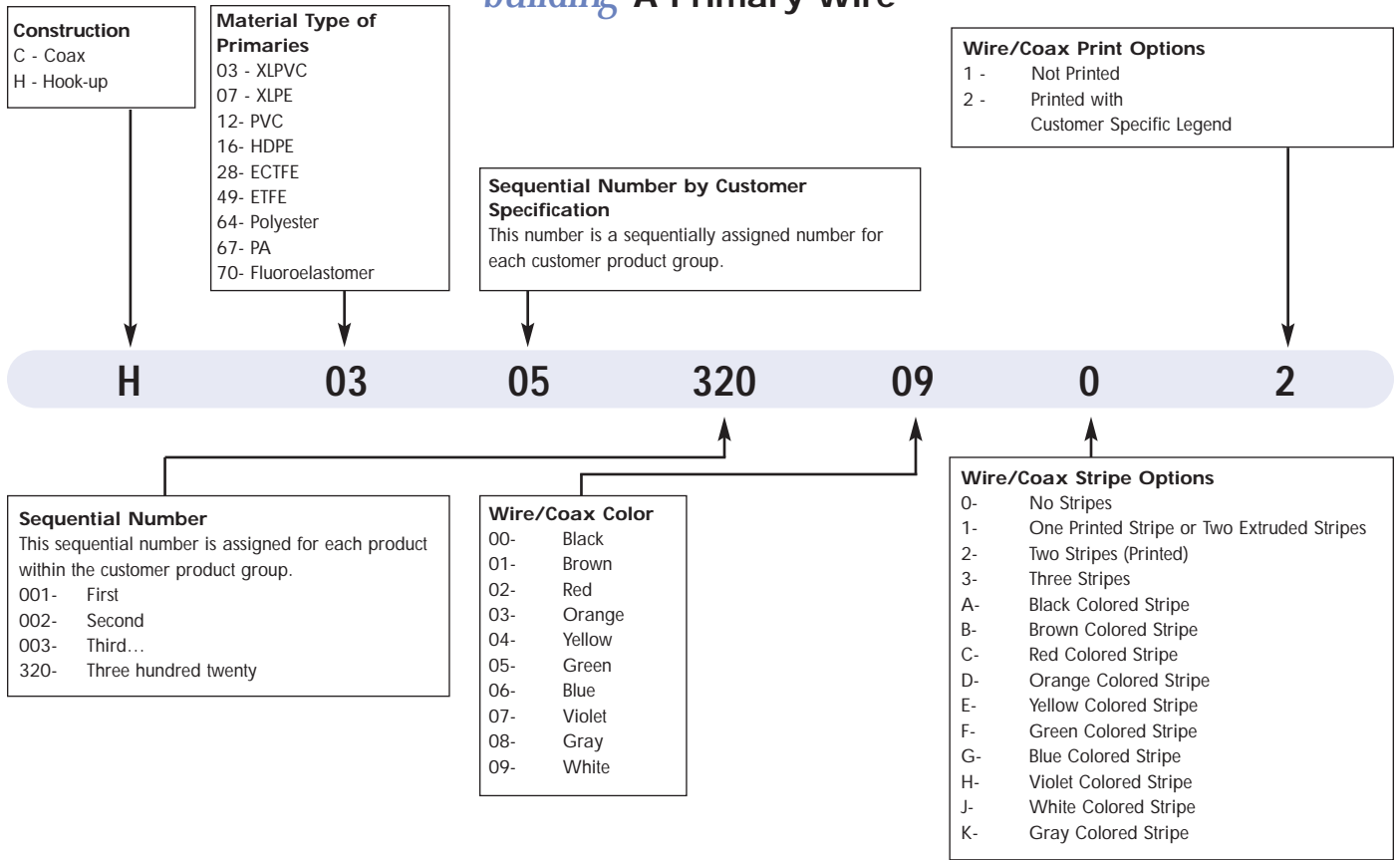

building A Multi Conductor Cable

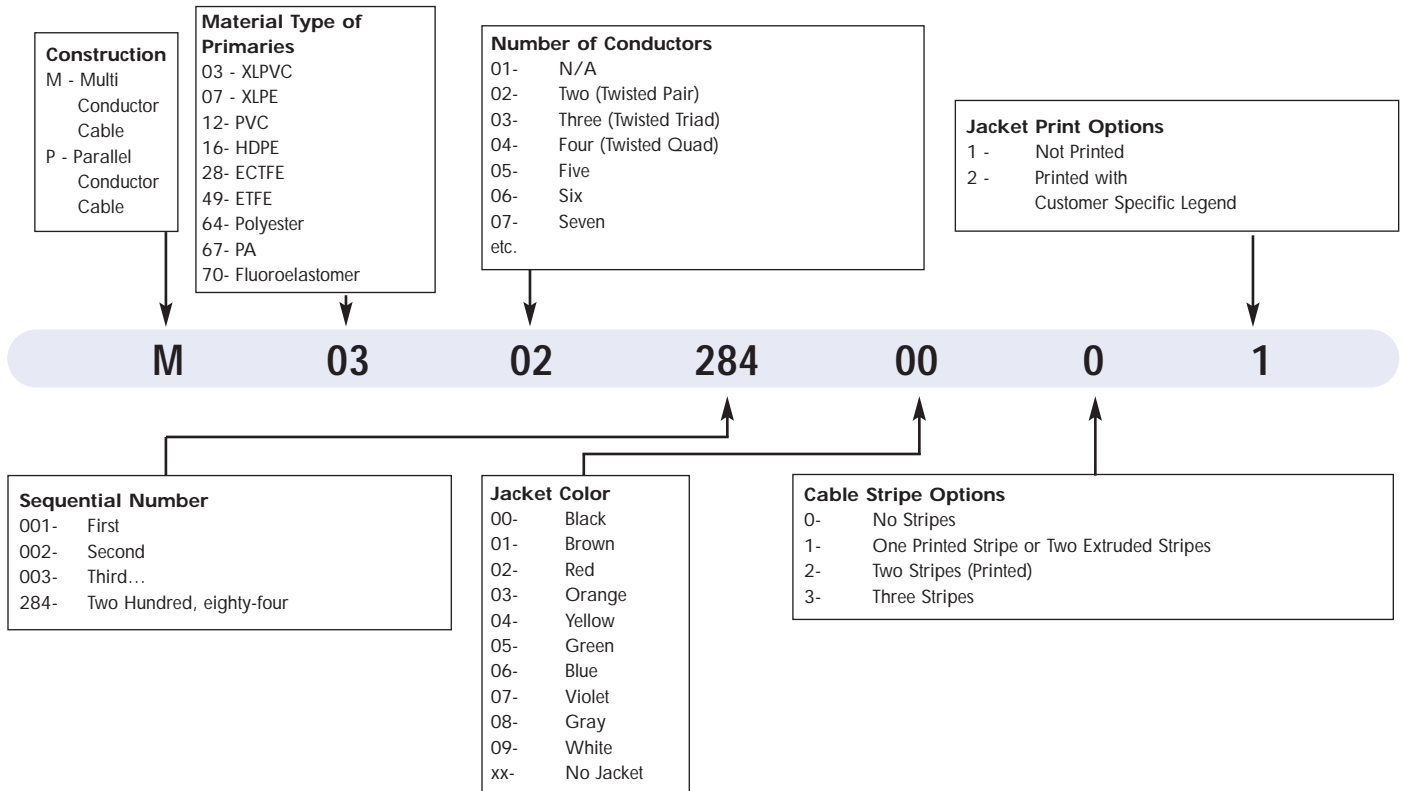

Society of Automotive Engineers (SAE)

SAE	Type	Description
J-156		Surface Vehicles Std; (R) Fusible Links [per J1128, Type TWP tests] (.35, .5, .8, 1, 2, 3, 5, & 8mm²)
J-1127		Surface Vehicles Std; Battery Cable (SAE 6 ~ 4/0, Metric 13, 19, 32, 40, 50, 62, 81, 103 mm²)
J-1127	STT	Starter or Ground, Thin Wall, Thermoplastic Insulated
J-1127	SGT	Starter or Ground, General Purpose, Thermoplastic Insulated
J-1127	STR	Starter or Ground, Thin Wall, Thermoset Elastomer (Synthetic Rubber) Insulated
J-1127	SGR	Starter or Ground, General Purpose, Thermoset Elastomer (Synthetic Rubber) Insulated
J-1127	STX	Starter or Ground, Thin Wall, Crosslinked (X) Polyolefin Insulated
J-1127	SGX	Starter or Ground, General Purpose, Crosslinked (X) Polyolefin Insulated
J-1127	STE	Starter or Ground, Thin Wall, Thermoplastic Elastomer Insulated
J-1127	SGE	Starter or Ground, General Purpose, Thermoplastic Elastomer Insulated
J-1128		Surface Vehicles Std; Low-Tension Primary Cable (SAE 8 ~ 24, Metric .22, .35, .5, .8, 1, 2, 3, 5, 8 mm²)
J-1128	TWP	Thin Wall, Thermoplastic Insulated
J-1128	GPT	General Purpose, Thermoplastic Insulated
J-1128	HDT	Heavy-Duty, Thermoplastic Insulated
J-1128	STS	Standard-Duty, Thermoset Elastomer (Synthetic Rubber) Insulated
J-1128	HTS	Heavy-Duty, Thermoset Elastomer (Synthetic Rubber) Insulated
J-1128	TXL	Thin Wall, Crosslinked (X) Polyolefin Insulated
J-1128	GXL	General Purpose, Crosslinked (X) Polyolefin Insulated
J-1128	SXL	Special Purpose, Crosslinked (X) Polyolefin Insulated
J-1128	TWE	Thin Wall, Thermoplastic Elastomer Insulated
J-1128	GTE	General Purpose, Thermoplastic Elastomer Insulated
J-1128	HTE	Heavy-Duty, Thermoplastic Elastomer Insulated
J-1560		Surface Vehicles Std; Low tension Thin Wall Primary Cable (SAE 8 ~ 24, Metric .22 ~ 8mm²)
J-1560	TWP	Thin Wall, Thermoplastic Insulated
J-1560	TXL	Thin Wall, Crosslinked (X) Polyolefin Insulated
J-1560	TWE	Thin Wall, Thermoplastic Elastomer Insulated
J-1678		Low Voltage, Ultra Thin Wall primary Cable
J-1678	Uxx	U - 0.20mm (0.008") Wall thickness
J-1678		W - 0.25mm (0.010") Wall thickness
J-1678	xTx	T - Thermoplastic
J-1678		X - Thermoset
J-1678	xxA	A - 85°C; 3000 hr Temp. Class Rating
J-1678		B - 100°C; 3000 hr Temp. Class Rating
J-1678		C - 125°C; 3000 hr Temp. Class Rating
J-1678		D - 150°C; 3000 hr Temp. Class Rating
J-1678		E - 175°C; 3000 hr Temp. Class Rating
J-1678		F - 200°C; 3000 hr Temp. Class Rating
J-1678		G - 225°C; 3000 hr Temp. Class Rating
J-1678		H - 250°C; 3000 hr Temp. Class Rating
J-1939		Draft: Serial Control and Communications Vehicle Network - (Class C)
J-1939	/11	Physical Layer - 250K bip/s Shielded Twisted Pair [.5mm ² (20 AWG), 120 ± 12 ohm @ 1MHz]
J-1939	/12	Preliminary: Twisted Quad Transmission Cable [.5mm ² (20 AWG), 75 ± 5 ohm @ 1MHz]
J-1939	/15	Reduced Physical Layer - 250K bits/s Un-shielded Tw Pr (UTP) [.5mm ² (20 AWG) or .8 mm ² (18 AWG), 120 ± 12 ohm @ 1 MHz]
J-1939	/21	Data Link Layer
J-1939	/31	Recommended Practice for Serial Control and Communications
J-1939	/71	Vehicle Applications Layer
J-1939	/73	Applications Layer - Diagnostics

8 Japanese Automotive Standard Organization (JASO) Abbreviations

Specification	Abbreviation	Note	Description
D 608-92	AEX		Crosslinked Polyethylene (XLPE 120°C Rated: .5f/20/.18, .5/7/.32, .75f/30/.18, .85/11/.32, 1.25f/50/.18, 1.25/16/.32, 2.0/26/.32, 3.0/41/.32, 5.0/65/.32, 8.0/50/.45 mm ² - colors: blk, wht, rd, grn, yel, brn, blu)
D 608-92	AVX		Crosslinked Vinyl (XLPVC 100°C Rated: .5/20, .75/30, 1.25/50, 2/26/37, 3/41, 5/65, 8/50, 15/84 mm ² colors: blk, wht, rd, grn, yel, brn, blu)
D 611-86	AVS	Thin Wall	Crosslinked Vinyl (XLPVC -100°C Rated: .3/7, .5/7, .85a/16, .85b/11, 1.25/16, 2/26, 3/41, 5/65 mm ² , no color specified)

Other Japanese Abbreviations

Abbreviation	Note	Description
AEX		Crosslinked Polyethylene (XLPE - .5/20, .75/30, 1.25/50, 2/26 or /37, 3/41, 5/65, 8/50, 15/84 mm ²)
AEX	Flexible	Crosslinked Polyethylene (XLPE 120°C Rated: .5f/20/.18, .5/7/.32, .75f/30/.18, .85/11/.32, 1.25f/50/.18, 1.25/16/.32, 2.0/26/.32, 3.0/41/.32, 5.0/65/.32, 8.0/50/.45 mm ²)
AESSX	Super Thin wall	Crosslinked Polyethylene (XLPE - .5f/19, .75f/19, 1.25/19, 1.25f/37, 2f/37 mm ²)
APEXH		Crosslinked Polyethylene Coax (XLPE - 0.5 mm ² 20/.18 mm BC XLPE BSH PVC JAC 3.45 mm OD)
APXHT		Crosslinked Polyvinyl Chloride (XLPVC - .5 mm ² 19/0.19 mm TVSSX 0.5f)
AVFX	Flexible	Crosslinked Polyethylene (XLPE, 140°C rated; .3, .5, .85, 1.00, 1.25, 1.5, 2.0, 8.0, 10.0, 12.0, 15.0 mm ²)
AVSSX	Super Thin wall	Crosslinked Polyvinyl Chloride (XLPVC - .5f/19, .75f/19, 1.25/19, 1.25f/37, 2f/37 mm ²)
AVX		Crosslinked Polyvinyl Chloride (XLPVC - .5/20, .75/30, 1.25/50, 2/26, 2/37, 3/41, 5/65, 8/50, 15/84 mm ²)
AVX		Crosslinked Polyvinyl Chloride (XLPVC -1C-6C .5 mm ² (20/.18 mm) SHE050 - 6SHE050)
AVX		Crosslinked Polyvinyl Chloride (XLPVC - 10/63 [7/9] mm ²)
AVX		Crosslinked Polyvinyl Chloride (XLPVC 100°C Rated: .5/20, .75/30, 1.25/50, 2/26, 2/37, 3/41, 5/65, 8/50, 15/84 mm ²)
AVX	Flexible	Crosslinked Polyvinyl Chloride (XLPVC - 8f/7, 8f/22, 10f/7, 10f/22, 15f/7, 15f/36 mm ²)
AVXTA	Flexible	Crosslinked Polyvinyl Chloride (XLPVC - .5f/20, .75f/30 mm ²)
AVSX	Thin wall	Crosslinked Polyvinyl Chloride (XLPVC - 3/41 mm ² , wall = .60 mm (.0236"), OD = 3.60 mm (.1417"))
BXRA	(ABS)	Crosslinked Polyethylene (XLPE, 140°C rated; 2/C .5 mm ² 7 x 38/.05 mm 6.2 mm OD)
BXRA	(ABS)	Crosslinked Polyethylene (XLPE, 140°C rated; 2/C .3 mm ² 3 x 20/.08 mm 5.0 mm OD)
BXRA	(ABS)	Crosslinked Polyethylene (XLPE, 140°C rated; 2/C .5 mm ² 7 x 38/.05 mm 7.2 mm OD)
FL-CEX		Crosslinked Chlorinated Polyethylene (XLFL-CEX - .3/7, .5/7, .85/11, 1/13, 1.25/16, 1.5/19, 2/26, 3/41 mm ²)
FL-CEX	(AEX10)	Crosslinked Polyethylene (XLPE, 150°C rated; 8.0 mm ² & 10.0 mm ² - [.5-100 mm ²])
FRBXRA	(ABS)	Crosslinked Polyethylene (XLPE, 140°C rated; 2/C .3 mm ² 3 x 30/.08 mm 5.0 mm OD)
FRBXRA	(BK) (ABS)	Crosslinked Polyethylene (XLPE, 140°C rated; 2/C .3 mm ² 7 x 23/.05 mm 5.0 mm OD)
IRRAX A		Crosslinked Polyethylene (XLPE, 100°C rated; .3 mm ² & .5 mm ²)
SHSX	Flexible	Crosslinked Polyvinyl Chloride (XLPVC - 2/C 0.5f/19 mm ² XLPVC tw pr / tpc sws / PVC jkt, 2SH050)
SHSXT	Flexible	Crosslinked Polyvinyl Chloride (XLPVC - 2/C 0.5f/19 mm ² XLPVC tw pr / tpc sws / PVC jkt, 2SH050)
TVSSX		Crosslinked Polyvinyl Chloride (XLPVC - .5 mm ² 19/0.19 mm [tinned] TVSSX 0.5f)
TOKAI		Crosslinked Polyvinyl Chloride (XLPVC - 1/C-3/C .5 mm ² 20/.18 mm XLPVC tw pr / serve shield / PVC jkt)
APXHTSHE		Crosslinked Polyethylene (XLPE - 1/C .5 mm ² 20/.18 mm XLPE Braid PVC jkt 3.45 mm OD)

Note: "f" denotes flexible conductor

International Organization for Standardization (ISO) Abbreviations

ISO	Class	Description
6722-1	A	-40°C to + 85°C, 50 Vrms (sizes: .5, .75, 1, 1.5, 2.5, 4, 6, 10, 16, 25, 35, 50, 70, 95, 120 mm ²)
6722-1	B	-40°C to + 100°C, 50 Vrms (sizes: .5, .75, 1, 1.5, 2.5, 4, 6, 10, 16, 25, 35, 50, 70, 95, 120 mm ²)
6722-1	C	-40°C to + 125°C, 50 Vrms (sizes: .5, .75, 1, 1.5, 2.5, 4, 6, 10, 16, 25, 35, 50, 70, 95, 120 mm ²)
6722-1	D	-40°C to + 155°C, 50 Vrms (sizes: .5, .75, 1, 1.5, 2.5, 4, 6, 10, 16, 25, 35, 50, 70, 95, 120 mm ²)
6722-1	E	-40°C to + 175°C, 50 Vrms (sizes: .5, .75, 1, 1.5, 2.5, 4, 6, 10, 16, 25, 35, 50, 70, 95, 120 mm ²)
6722-1	F	-40°C to + 200°C, 50 Vrms (sizes: .5, .75, 1, 1.5, 2.5, 4, 6, 10, 16, 25, 35, 50, 70, 95, 120 mm ²)
6722-1		Road Vehicles - Unscreened Low-tension cables, Part 1 test methods
6722-2		Road Vehicles - Unscreened Low-tension cables, Part 2 requirements
6722-3		Road Vehicles - Unscreened Low-tension cables, Part 3 Conductors & dimensions for thick-wall insulated cables
6722-4		Road Vehicles - Unscreened Low-tension cables, Part 3 Conductors & dimensions for thin-wall insulated cables

Deutsches Institut fur Normung (DIN) Abbreviations

ISO	Construction Material	Type	Description
76 722			Strassenfahrzeuge Niederspannungsleitungen

Wire Types:

76 722		FL	Low-voltage cable, road vehicles
76 722		FZL	High-voltage ignition cable, road vehicles

Special Design Features:

76 722	F		Flat cable
76 722	M		Compound conductor or conductor materials other than electrolytic copper or resistance alloys
76 722	R		Reduced wall thickness of insulating
76 722	S		Thickness of insulation greater than that specified in DIN ISO 6722, Part 3, with conventional insulation
76 722	U		Thickness of insulation as specified in DIN ISO 6722, Part 5
76 722	W		Resistance Conductor, effective resistance core for resistance ignition cables
76 722	Z		Multicore, splittable cable

Shielding and Additional Processes:

76 722	B		Taped screen
76 722	C		Copper wire braiding
76 722	D		Copper wire cover
76 722	G		Glass fiber braiding
76 722	J		Impregnated
76 722	L		Varnish
76 722	P		Insulating film
76 722	T		Textile Braiding

Insulation and Jackets:

76 722	Y	PVC	Polyvinyl-chloride
76 722	YK	PVC	Polyvinyl-chloride cold resistant
76 722	YW	PVC	Polyvinyl-chloride heat resistant
76 722	X	XL PVC	Polyvinyl-chloride, cross-linked
76 722	2Y	PE	Polyethylene
76 722	2X	XL PE	Polyethylene, cross-linked
76 722	4Y	PA	Polyamide
76 722	5Y	PTFE	Polytetrafluoroethylene
76 722	6Y	FEP	Fluorinated ethylene propylene copolymer
76 722	7Y	ETFE	Ethylene tetrafluoroethylene
76 722	9Y	PP	Polypropylene
76 722	53G	CPE	Chlorinated polyethylene
76 722	33X	XL PES	Polyester, cross-linked
76 722	41X	XL PO	Polyolefin copolymer, cross-linked

NOTE: In foamed materials the code is preceded by a "0", e.g. 02Y = foamed or cellular PE

AWG vs mm²

SIZE		GOVERNING SPECIFICATION	per SAE J1127 & SAE J1128		per ASTM B286'	Data for respective conductors using UL 1581	
AWG	mm ²	DESCRIPTION	AWG sizes (Min cma)	mm ² sizes (Min mm ²)	AWG sizes (Min cma)	using 20-29 AWG strds (Min cma)	using 30-36 AWG strds (Min cma)
4/0	103.0	SAE J1127	205500	98.5	210900	207368	--
3/0	81.0	SAE J1127	158600	77.6	167200	164444	--
2/0	62.0	SAE J1127	125100	59.8	133000	130438	--
1/0	50.0	SAE J1127	98980	48.3	106400	103488	--
1	40.0	SAE J1127	77790	38.1	83600	82016	--
2	32.0	SAE J1127	62450	31.1	66500	65033	--
4	19.0	SAE J1117	37360	18.3	42615	40905	--
6	13.0	SAE J1127	24538	12.1	26818	25715	--
8	8.0	SAE J1128	14810	7.23	16983	16180	--
10	5.0	SAE J1128	9343	4.65	10500	10172	10069
12	3.0	SAE J1128	5833	2.91	6500	6399	6334
14	2.0	SAE J1128	3702	1.85	4100	4028	3987
16	1.0	SAE J1128	2336	1.13	2600	2528	2503
18	.80	SAE J1128	1537	0.760	1900	1588	1571
20	.50	SAE J1128	1072	0.508	1216	1000	989
22	.35	SAE J1128	681	0.324	754	627	621
24	.22	SAE J1128	405	0.205	475	396	392
26	.13	ASTM B 286 / UL 1581	--	--	304	248	--
28	.08	ASTM B 286 / UL 1581	--	--	175	156	--
30	.05	ASTM B 286 / UL 1581	--	--	112	98	--

Note: ASTM B 286 also has maximum resistance values depending on plating and core material type.

Temperature Conversion Chart

Degrees Centigrade = $5/9 (\text{°F} - 32)$ Degrees Fahrenheit = $(9/5 * \text{°C}) + 32$

°C	°F	°C	°F	°C	°F	°C	°F
- 65	- 85	10	50	85	185	160	320
- 60	- 76	15	59	90	194	165	329
- 55	- 67	20	68	95	203	170	338
- 50	- 58	25	77	100	212	175	347
- 45	- 49	30	86	105	221	180	356
- 40	- 40	35	95	110	230	185	365
- 35	- 31	40	104	115	239	190	374
- 30	- 22	45	113	120	248	195	383
- 25	- 13	50	122	125	257	200	392
- 20	- 4	55	131	130	266	250	482
- 15	5	60	140	135	275	300	572
- 10	14	65	149	140	284	350	662
- 5	23	70	158	145	293		
0	32	75	167	150	302		
5	41	80	176	155	311		

Conversion Factors

meters	to	inches	multiply by	39.37
meters	to	feet	multiply by	3.281
meters	to	millimeters	multiply by	1000
kilometers	to	meters	multiply by	1000
inches	to	millimeters	multiply by	25.4
miles	to	kilometers	multiply by	1.609
pounds	to	grams	multiply by	453.59
grams	to	pounds	divide by	453.59
inches	to	meters	multiply by	0.0254
feet	to	meters	multiply by	0.3048
millimeters	to	meters	multiply by	0.001
meters	to	kilometers	multiply by	0.001
millimeters	to	inches	divide by	25.4
kilometers	to	miles	multiply by	0.6214

Testing Capabilities

Routine Specification Testing

- SAE J-1128, J-1127, J-1678, J-156
- Major OEM specifications

Special testing for automotive wire & cable

- Flexure Endurance
- Pinch Resistance
- Abrasion Resistance
- Degree of Crosslinking
- Flame Resistance
- Fluid Immersion & Aging Resistance

Special material testing and analysis

- DSC/TGA/DMA
- Density
- Volatiles
- Instron Testing
- Hot Cut Through
- FT-IR Heat Aging Test
- Viscosity
- Cold Bend
- Short Circuit
- Hot Modulus
- Shield Effectiveness Testing
- Ozone Resistance
- Controlled Current

Note: In-House Fabrication- Judd Wire has its own conductor fabrication department. This makes it possible for Judd to have control over the supply and quality of many of the conductors used in its product line. The finished size of the conductor ranges from 12 to 26 AWG and the single end size range is 27 to 44 AWG. Many different constructions are made ranging from 7 to 266 individual strands. Conductors fabricated from bare copper, tin-coated copper and high flex life alloy are produced in-house. Special custom conductors can be designed for unique applications as well as quick deliveries for sample orders or emergency situations.

Abrasion Resistance

Ability to resist surface wear. A measure of the ability of a wire covering or jacket to resist surface wear or damage by mechanical means.

ABS Cable

Anti-lock Brake System cable, which usually consists of a twisted pair of primary wire and a jacket that is resistant to abrasion and certain chemicals, and has good flex endurance.

Accelerated Aging / Life Test

A test in which voltage, temperature, etc. are increased above normal operating values to obtain observable deterioration in a relatively short period of time.

Adhesion

The physical joining of two substances. Adhesion is also used to describe "strip force", which is the force required to strip the insulation away from the conductor, or the jacket away from the cabled singles.

Alloy

A metal formed by combining two or more different metals to obtain desirable properties.

Ambient

Environmental condition that an item is exposed to, such as temperature or humidity.

Ampere

The basic unit of electrical current. A wire might have a rating which limits the acceptable amperage in order to prevent overheating.

Annealed Wire

Conductor which has been softened by slow heating during manufacture, in order to remove the effects of cold-working. Sometimes referred to as soft drawn wire.

ANSI

American National Standards Institute.

ASTM

American Society for Testing and Materials.

Attenuation

Loss of power or signal in a cable, expressed in decibels (dB) per unit length. This is measured in a lab at one or more frequencies as determined by a specification.

Average Wall Thickness

The average of minimum and maximum walls. The method of measuring these may be determined by specification (see also Nominal Wall).

AWG

American Wire Gage, a system of conductor sizes that connects strand sizes and constructions with cross-sectional areas and therefore current-carrying capacity. These roughly correspond to most metric sizes.

Bend Radius

The radius of curvature that a wire or cable can bend without causing any damaging effects.

Braid

Woven bare metallic or tinned copper wire used as shielding for wires and cables and as ground wire for batteries or heavy industrial equipment. Also, fibrous members interwoven in cylindrical form to form a protective outer covering over a conductor or cable.

Braid Angle

The angle between the axis of a cable and any strand of a braid. A higher angle results in greater flexibility.

Breakdown Voltage

The voltage at which the insulation between two conductors or a conductor and a shield breaks down (shorts out). Refers also to a test employing a salt-water bath, where a certain voltage must be achieved without breakdown.

Bunched Stranding

Term applied to a group of strands twisted together in a random manner in the same direction in one operation, without regard to geometric arrangement of specific strands.

Cable

Insulated wire of fairly large size, or a multi-conductor insulated wire that is jacketed together into one unit.

Note: "Wire" and "cable" are sometimes used interchangeably.

CA-6

A high strength copper alloy used in special applications.

Capacitance

Storage of electric charge in a cable as a function of applied voltages, as measured in a lab. There are several forms of this measurement.

Circuit

A complete electrical path, in which power is transmitted from a source (such as a battery) to components that can perform useful work or develop a useful signal.

Circular Mil

A unit of area equal to a square mil x 0.7854. Used chiefly in specifying cross-sectional areas of round conductors.

CMA

Circular mil area, or the metallic cross-sectional area of a conductor, expressed in circular mils.

Coaxial Cable

A cable consisting of two cylindrical conductors with a common axis. The outer conductor, or shield, is also commonly used to prevent external radiation from affecting the signal in the inner conductor, and usually consists of woven strands of wire or metalized tape.

Cold Bend

Test procedure whereby a sample of wire or cable is wound around a metal cylinder of a specified size within a cold chamber. The sample is then removed and examined for defects or deterioration.

Compressed Conductor

A stranded conductor that has been put through a sizing die to reduce the diameter, slightly flattening the outermost strands in the process.

Concentric Stranding

Referring to a single conductor constructed of layers over a central core, forming a geometric pattern which is constant throughout the wire, as opposed to a bunched stranding.

Conductor

Precisely speaking, a metal component of a wire which carries electrical current. However, in some contexts it can refer to the insulated wire(s) which, together with a jacket, make up a cable.

Copolymer

A polymer resulting from addition polymerization of two different monomers. The resulting copolymers have properties different from either of the homopolymers from the two monomers or the mechanical mixture of the homopolymers.

Copper Alloy

Copper to which has been added other elements in specific amounts while in the molten state. This results in improvement of certain properties, such as strength and corrosion resistance.

Cross-linked (XL)

A term denoting intermolecular bonds between long chain molecules, effected by chemical or irradiation techniques. Judd's cross-linked products are irradiation cross-linked.

Crosslinked Polyethylene (XLPE)

Cross-linking converts PE from a thermoplastic to a material with thermosetting properties. Properties are quite similar to conventional PE except for a significant improvement in heat resistance, mechanical properties (including toughness and abrasion resistance), aging characteristics, and freedom from environmental stress cracking.

Curing

The change in a material's physical properties by chemical reaction, which may be carried out by heat, irradiation or moisture.

Dielectric Breakdown

See breakdown voltage.

Drain Wire

In a cable, the uninsulated wire in intimate contact with a shield to provide for easier termination of such a shield to electrical ground.

Elastomer

A class of elastic, long-chain polymers capable of being crosslinked to produce elastic compounds with high-temperature rating and excellent resistance to physical abuse.

ETFE

Ethylene-TetraFluoroEthylene. Usually unirradiated in automotive applications, it is a tough, high temperature material.

Filler

- 1) A member of a multi-conductor cable used to maintain a round shape and/or to fill voids.
- 2) A pressured inner-jacket layer.
- 3) An inert material added to a polymer resin to reduce cost or enhance certain properties.

Flame Resistance

Ability of a material to self-extinguish a flame once the source of heat is removed.

Flex Life

Ability of a conductor, wire, or cable to withstand repeated bending, as determined by a specified testing apparatus.

Flexibility

That quality of a cable or cable component which allows for bending under the influence of an external force.

Fluoroelastomer

An elastomer containing fluorine, such as Judd's J5™. The fluorine component is tightly bound to the polymer backbone and greatly increases the resistance to chemical attack.

Halogen-Free

Materials that do not contain elements known as Halogens (such as Chlorine Bromine and Fluorine), in order to satisfy certain environmental requirements.

Hard-Drawn Wire

Wire that has been drawn to final size without annealing, so as to approach the maximum tensile strength possible.

Homopolymer

A polymer resulting from one kind of monomer.

Hook-Up Wire

Insulated wire used for low current, low voltage applications.

ID

Inner Diameter

IEEE

Institute of Electrical and Electronics Engineers

ISO

International Standards Organization

Lay Length

The axial length of one turn of the helix of a wire or member. Usually 8 to 15 times the diameter of the construction.

Life Cycle

A test to determine the length of time before failure in a controlled, usually accelerated, environment.

Metric Size or Metric Conductor

Refers to constructions and strand sizes commonly expressed in metric units, usually originating from European specifications. Strand sizes are in millimeters, and conductor sizes are in square millimeters. Many of the typical strandings also exist in the AWG system, but in some cases there is no convenient match.

Mil

0.001" - One 1000th of an inch. A unit used in measuring diameter of wire or thickness of an insulation over a conductor.

Millimeter (mm)

One thousandth of a meter. One millimeter (or 1mm) equals 0.03937 inches.

Minimum Wall Thickness

The smallest distance between the outer rim of the insulation and the outermost strand of the conductor. Often given as a requirement.

Moisture Resistance

The ability of a material to resist absorbing moisture from the air or when immersed in water.

Monomer

The basic chemical precursor unit used in building a polymer. The monomer becomes the repeating unit in the molecular structure polymer chain.

Multiple-Conductor Cable

A combination of two or more conductors cabled together and insulated from one another and from the sheath.

Nominal Wall Thickness

Name or dimension by which a wall thickness is identified by a specification. Where a wire OD is specified, the target wall thickness may not equal the implied nominal, although the wire is still required to meet certain test requirements.

OD

Outside Diameter

Parallel Cable

A cable in which two or more untwisted conductors or insulated wires are jacketed.

PE

See Polyethylene

Plastics

High polymeric substances, including both natural and synthetic polymer resin but excluding the rubbers, that are capable of flowing under heat and pressure at one time or another.

Polyamide (PA)

A group of polymers which are used for wire and cable jacketing, suitable for ultra-thin wall constructions.

Polyester (PES)

A material used for wiring in hydrocarbon environments (such as gasoline) with temperature ratings between those of crosslinked polyolefins and fluoroelastomers. It is suitable for ultra-thin wall constructions.

Polyethylene (PE)

A thermoplastic material composed of polymers of ethylene. Polyethylene has excellent electrical properties for wire and cable insulation. It features superior abrasion and solvent resistance, moisture resistance, and durability. Flame retardant types of polyethylene are available. See also XLPE.

Polymer

A compound formed by polymerization which results in the chemical union of monomers or the continued reaction between lower molecular weight polymers.

Polyolefin

A family of thermoplastics based on the ethylene family of hydrocarbons. Includes polyethylene and polypropylene. Cross-linked versions are XLPOs.

Polyurethane (PU)

Used for jacketing layer in cables, it has good abrasion and solvent resistance. Cross-linked types (XLPU) have further enhanced properties.

Polyvinyl Chloride (PVC)

A general purpose thermoplastic material composed of polymers of vinyl chloride. Many different formulations are available including grades for high temperatures, cold resistance, flame resistance, deformation resistance, etc. Dielectric strength is excellent and flexibility is very good. Some formulations may have limitations when considering toughness, moisture resistance, and resistance to chemicals.

Pressured Layer

Material extruded onto a conductor or cable construction with sufficient pressure to fill in the interstices of the conductor or cable components. Also called the "Filler" in some cables.

Primary Wire

One or more insulated conductors that resides within a jacket, often called "single." Note: "primary" and "single" are often used interchangeably. In addition, a manufacturer may produce a primary or single without jacketing it.

RFI

Radio Frequency Interference

Rope Stranding

A conductor that is composed of a group of stranded members twisted together like a rope.

SAE

Abbreviation for Society of Automotive Engineers. Many basic wire types are specified by SAE J 1128.

SEI

Sumitomo Electric Industries, Ltd.

Sheath

The outer covering or jacket of a multiconductor cable.

Shield

A metallic layer placed around an insulated conductor or group of conductors to prevent electrostatic or electromagnetic interference between the enclosed wires and external fields.

Shield Coverage

The physical area of a cable that is actually covered by the shielding material and is expressed in percent.

Silicone Block

Soft material that is pressured into a conductor during stranding, in order to have an anti-wicking property.

Silicone Blocked Bare Copper (SBB)

Bare copper strands twisted together with silicone blocking agent applied between and around each strand to prevent fluid wicking.

Silicone Blocked Tin Plated Copper (SBT)

Tin plated copper strands twisted together with silicone blocking agent applied between and around each strand to prevent fluid wicking.

Specific Gravity

The weight of a material divided by the weight of water of the same volume.

Spiral Wrap

The helical wrap of a material over a core.

Splice

A connection of the conductors in a wire or cable to provide good mechanical strength as well as good conductivity.

Strip Force

The force required to remove a specified length of insulating material from the conductor it covers.

Tape

A woven or cut strip of fabric, paper, or film material used as a separator or electrically conductive component.

Temperature Rating

The maximum temperature at which the insulating material may be used in continuous operation without substantial deterioration of its basic properties.

Tensile Strength

The pulling stress required to break a given specimen, often measured in pounds per square inch (psi) or in Pascals. Not the same as break strength, which is the maximum force required without regard to the cross-sectional area.

Terpolymers

A polymer resulting from addition polymerization of three different kinds of monomers.

Thermal Shock

A testing regimen in which samples are conditioned in an oven at a high temperature for a short period(s) of time, alternating with exposure in a refrigeration chamber in some cases.

Thermoplastic

A classification of resin that can be readily softened and re-softened by repeated heating.

Thermoset

A material which hardens or sets by heat, chemical or radiation cross-linking techniques and which, once set, cannot be re-softened by heating.

Tinned Copper

Conductor in which each individual strand has gone through a tin-plating bath, which aids in soldering and in inhibiting corrosion.

Top Coat

Metal coating on bunched or stranded bare copper conductor. The metal coating is applied on the final conductor construction. Most common coating material is tin.

Transmission Wire

Primary Wire with special properties suitable for installation within an electronic style transmission.

Tube Layer

Material extruded onto a conductor or cable construction which forms a tube, and which is easier to separate than a pressured layer.

Twisted Pair

Typically the inner portion of a cable consisting of two insulated conductors ("primaries") twisted together.

Voltage Rating

The highest voltage that may be continuously applied to a wire or cord in conformance with standards or specifications.

VW-1

A flammability rating established by Underwriters Laboratories for wires and cables that pass a specially designed vertical flame test, formerly designated FR-1.

Wicking

The travel of a fluid along a wire by capillary action, either through the spaces amongst the conductor strands or between jacket layers.

- *Achieved QS-9000 / ISO-9002 at TF in June, 1996*
- *Achieved ISO-9001 at SM in June 1997*
- *Achieved QS-9000 at SM in November 1997*
- *Created Corporate Quality Policy, 1994:*

It is the policy of JUDD WIRE, INC. to deliver

“Total Customer Satisfaction Through Continuous Improvement.”

*A Comprehensive Guide to
Reference Information
in an Easy-to-Follow Format
provided by*



JUDD WIRE INC.

 A member of the Sumitomo Electric Industries group of companies

We solve wire and cable problems

JUDD WIRE INC.
 Headquarters and
 Manufacturing Facility
 124 Turnpike Road
 Turners Falls, Ma 01376
 (413) 863-4357 (tel)
 1-800-545-5833
 (413) 863-2305 (fax)

Automotive Application Sheet

Return this form for immediate engineering and cost analysis of your wire and cable requirements

Date: _____ Vehicle _____ Platform: _____
 Application _____ Model Yr: _____
 Reference Specification _____

Conductor Material

- Annealed Bare Copper
- Tin Coated Copper
- Silver Plated Copper
- Other _____

Insulation

Primary

- TPE
- XLPVC
- XLPE
- XLFE
- XLPU
- XLPES
- Other _____

Jacket

- TPE
- XLPVC
- XLPE
- XLFE
- XLPU
- XLPES
- Other _____

Physical Construction Checklist

Hook-up Wire

AWG/mm² _____ Wall Thickness _____
 O.D. _____ # of colors/stripes _____ Put ups _____

Cable Component

of Conductors _____ # of Pairs _____ Pair Lay _____
 Shielding _____ Drain _____
 Coverage/Overlap _____ Conductor/Pair JKT _____

Jacketed Cable

Cable lay _____ Shielding _____ Drain _____
 Coverage/overlap _____ Cable Jacket _____
 O.D. _____

Environmental

Heat Resistance _____ Battery Acid _____
 Fluid Compatibility _____ Antifreeze/Coolant _____

Wire Requirements

Tensile Strength _____
 Elongation _____
 Heat Age Retention _____
 Nom OD/Tolerance _____
 Nom Wall _____
 Min Wall _____
 Cold Bend _____
 Flame _____
 Pinch _____
 Abrasion _____
 Solder Resistance _____
 Conductor Solderability _____

Jacket Assembly

Flex Life _____
 Cold Bend _____
Fluid
 Ref Fuel C _____
 Methanol/Ref Fuel C _____
 Diesel Fuel _____
 Engine Oil _____
 Power Steering Fluid _____
 Transmission Fluid _____

Cable Jacket

Nom Wall _____
 Nom OD/Tolerance _____
 Tensile Strength _____
 Elongation _____
 Heat Resistance _____
 Pinch _____
 Abrasion _____
 Moldability _____
 Adhesion _____
 Thermal Shock _____

Name _____
 Title _____ Company _____
 Address _____ City, State, Zip _____
 Telephone _____ Fax _____ email _____

Usage (EAU): _____
 Target Price: _____